

The Impinj Speedway antenna hub provides a low-cost opportunity to drive many antennas from a single fixed RAIN RFID reader. This antenna hub makes RAIN RFID monitoring applications requiring many antennas, including large, contiguous read zones and smart shelves, both cost-effective and easy to deploy.

Why Choose this Antenna Hub?

- Cost effective
- Simple to scale
- Easy to install

Maximum Antenna Connections

- 8 antennas with an Impinj Speedway R120
- 16 antennas with an Impinj Speedway R220
- 32 antennas with an Impinj Speedway R420

Antenna Port Numbering

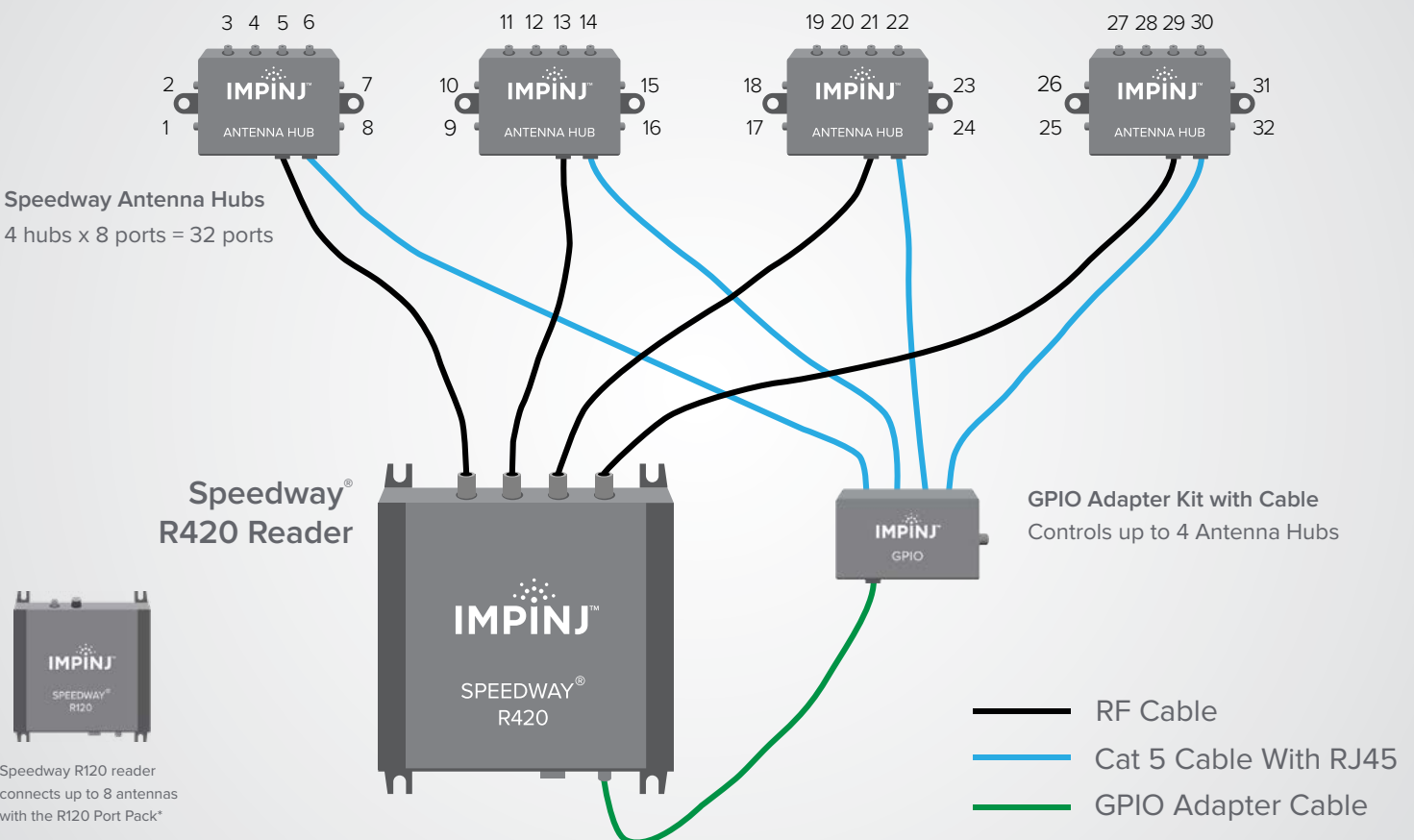



Impinj Speedway Readers Link Endpoints to Applications

Impinj Speedway readers are enterprise-class fixed readers with the performance, quality, and reliability necessary for maximum endpoint visibility.

Product Details	Speedway Antenna Hub	GPIO Adapter for Antenna Hubs
Dimensions	4 x 2.4 x 1 in (102 x 61 x 24 mm)	3.5 x 2.4 x 1 in (92 x 61 x 24 mm)
Weight	3.5 oz (100 g)	2.8 oz (80 g)
Power Supply	5V provided by the GPIO Adapter	5V provided by the Speedway reader
Power Consumption	25mA (80mW) max	5mA (20mW) max, nominal voltage is 3.3V I/O with 5V max
Connectors	RF Input: SMA Female 8 RF Outputs: SMA Female 1 Digital I/O: RJ45	1 GPIO Input: HD-15 (for connection to reader) 4 Digital I/O: RJ45 (one for each hub)
Mounting Options	Two 1/4 in mounting holes	Two 1/4 in mounting holes
Max Input Power	34 dBm	
Insertion Loss	1.3 dB Typical	
Isolation	36 dB Typical	
Return Loss	24 dBm Typical	
Antenna Hub Switching Speed	<200 μ s based on hardware design	
Device Switching Speed	~25 ms based on Speedway firmware	
Operating Temperature	-40 °C to 80 °C	-40 °C to 80 °C
Storage Temperature	25 °C	25 °C
Humidity	5% to 95%, non-condensing	5% to 95%, non-condensing
IP Rating	IP52	IP52
Frequency	860-960 MHz	
Certifications	FCC, CE, RoHS	FCC, CE, RoHS
Cables	RF cable maximum length: depends on environment/region, typical 1/2 dB per meter signal loss Digital cable (Cat5) for control, maximum length: 300 ft (100 m) if shielded 100 ft (30 m) if unshielded	HD-15: 1 ft cable for Speedway GPIO port included Custom HD-15 can be manufactured up to 100ft (30 m) max
Configuration	Octane Rshell, Speedway WebUI	
Antenna Port Numbering	1-32 on Antenna Hubs 1, 9, 17, 25 on native reader ports	
API	LLRP Tool Kit (LTK), Speedway Development Kit (SDK)	
Test Software	Impinj ItemTest	

SPEEDWAY ANTENNA HUB BENEFITS & FEATURES



Simple to Scale

Connect and control up to 32 antennas to a single Speedway reader and GPIO adapter



Cost Effective

Antenna intensive RAIN RFID deployments can connect up to 32 antennas



Performance

All the benefits of the Speedway reader but no new API's or extensive programming changes



Easy to Install Design

Enclosed electronics board with mounting tabs and LED's for system level feedback



Track Movement in Real-Time

Robust solution for popular item monitoring and other antenna-intensive RAIN applications



Robust, System Level Feedback

With system level feedback for reliable installations in real world conditions

*Speedway R120 Port Pack includes one Speedway Antenna Hub and one GPIO Adapter.